

The Clinical Outcomes, Blood Transfusions, And Modern Mitigation Strategies

James Nicholson¹, Omar Elboraey², Tarek Said³

¹Foundation Year 1, South Warwickshire University NHS Foundation Trust, UK, Jamesnicholson47@gmail.com
<https://orcid.org/0009-0009-0539-2975>

²Cardiology Speciality Trainee – Year 4, East Cheshire NHS Foundation Trust, UK, omar.elboraey@doctors.org.uk
<https://orcid.org/0009-0004-3473-3744>

³Intensive Care Medicine Consultant, Lancashire Teaching Hospitals NHS Foundation Trust, UK,
Tarek.said@lthtr.nhs.uk

Corresponding Author:

Omar Elboraey, Cardiology Speciality Trainee – Year 4, East Cheshire NHS Foundation Trust,
Macclesfield, Cheshire, UK, SK10 3BL

Email: Omar.elboraey@doctors.org.uk

<p>Keywords: Intensive care unit; Iatrogenic anemia; Diagnostic blood sampling; Blood conservation; Arterial lines; Blood transfusion</p>	<p>Abstract</p> <p>Background: Blood sampling causes significant blood loss in intensive care unit (ICU) patients. It is partially responsible for the development of anaemia in critically ill patients, which is strongly associated with poorer patient outcomes. Blood sampling also increases the demand for blood transfusions. Fortunately, methods to reduce blood loss have been developed, such as closed-circuit arterial lines and blood sampling optimisation. However, these practices are not widely implemented within ICU settings. Their introduction could significantly reduce iatrogenic blood loss and consequently improve patient outcomes.</p> <p>Objectives: To identify whether significant blood loss due to sampling is experienced by ICU patients.</p> <p>Methods: A retrospective, observational study was performed on non-bleeding, level 3 ICU patients with a length of stay ≥ 14 days. The volumes of blood lost due to blood sampling were collected and correlated against blood transfusion requirements, patient outcomes, and the maximum haemoglobin decline patients experienced after ICU admission.</p> <p>Results: 32 patients were included in the study. The mean (\pm standard deviation) total volume of blood loss due to sampling for individual patients was 578.0mL (± 242.3) with an average of 24.5mL/day (± 5.0) per patient. Discarded blood volumes represented 46.3% (± 3.5) of all blood lost by patients. Within the patient population, 37.5% of patients received a blood transfusion. Higher volumes of blood sampling were also strongly associated with higher mortality rates when compared with patients who survived to hospital discharge ($p = 0.0269$). All patients admitted to the ICU developed anaemia during their admission.</p> <p>Conclusions: Patients experience significant blood loss during their ICU admission. Higher volumes of blood sampling may contribute towards increased mortality for patients. Therefore, patients could benefit from the introduction of blood conservation methods.</p>
--	---

1. Introduction

The presence of anaemia in critical illness is a common finding but is difficult to prevent. It stems from the combination of two distinct processes: excessive blood loss and deficient red blood cell (RBC) production¹⁻³. A variety of different causes contribute to each process, which are summarised in Table 1. Many critically ill patients enter the intensive care unit (ICU) with anaemia, with the leading causes being due to surgery, trauma, haemorrhage and coagulopathies. Interestingly, however, patients who have not developed anaemia on ICU admission commonly do so during their stay, regardless of these factors⁴⁻⁶. The principal mechanisms contributing to anaemia in critically ill patients are summarised in (Table 1)

Blood sampling in critical care is a source of blood loss. Whilst blood lost from diagnostic testing may appear unassuming, patients with extensive ICU stays will experience the loss of large volumes of blood due to regular testing^{7,8}. Importantly, blood loss through sampling remains one of the few readily modifiable causes of blood loss in critical illness.

Table 1: Author made, adapted from references²⁻⁴. Causes of Anaemia in Critically Ill Patients. The different causes of anaemia in critical illness are categorised into those that cause loss of blood volume and RBC concentration, and those that prevent restorative erythropoiesis.

Causes of Blood Loss	Causes of Reduced RBC Production
Blood sampling	Reduced erythropoietin production
Haemorrhage and trauma	Bone marrow hypo-responsiveness
Surgical interventions	Impaired iron metabolism
Abnormal coagulation	Nutrient deficiencies
Haemolysis	
Reduced RBC lifespan	

Iatrogenic anaemia is of particular importance in the ICU, where blood volumes of approximately 18-86mL can be routinely removed for sampling per day^{7,9,10-12}. Hence, for patients with prolonged stays in the ICU, significant blood loss may be observed. Furthermore, for every 100mL of blood taken for sampling, a 0.7g/L reduction in haemoglobin and 1.9% fall in haematocrit¹³ is witnessed, emphasising the importance of minimising blood loss. However, it has been suggested that half of blood tests in ICUs are unnecessary, provide little clinical value and do not benefit patient outcomes^{14,15}

Arterial lines have been a mainstay of monitoring in ICU for decades¹⁶. Arterial lines are used for continuous arterial blood pressure monitoring and as a site for frequent blood sampling (Fig. 1). However, a major drawback of blood sampling from conventional arterial lines is the discarded volumes of blood removed at the start of a blood draw. On average, 13-15mL of blood is discarded per patient each day^{9,10,17} and is responsible for approximately 30% of iatrogenic blood loss¹² in the ICU. This discarded blood volume is required for each sampling episode to remove the flush solution from the arterial line. These volumes cannot be returned into the arterial line as it is no longer sterile and risks contamination and infection of the patient's circulating blood¹⁸.

Modern closed-circuit arterial lines eliminate discarded blood volumes when sampling from them. They operate via a blood reservoir pulling the initial 'flushed' arterial blood past the sampling port. The sampling port can then be accessed for sampling the accurate physiological concentration of blood. After the blood draw is complete, the blood reservoir can be reinfused, and the arterial line is flushed¹⁹ (Fig. 1). This process mitigates the need to discard blood.

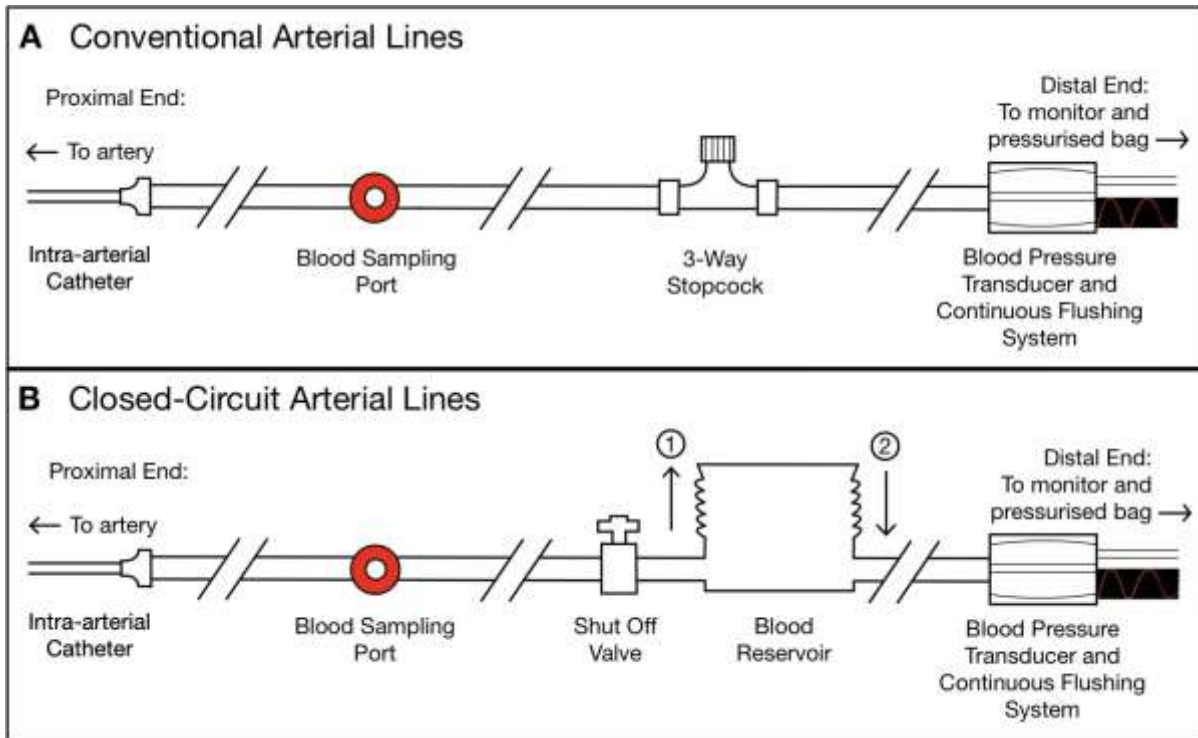

Figure 1: Author made, adapted from references ^{18, 19}. Comparison of Conventional and Closed-Circuit Arterial Lines. A) Conventional arterial lines contain an intra-arterial catheter, blood sampling port, 3-way stopcock, blood pressure transducer and a continuous flushing system. It does not contain a device for the conservation of blood when the line must be cleared before taking blood samples. Blood is discarded from conventional arterial lines. B) Closed-circuit arterial lines contain an intra-arterial catheter, blood sampling port, shut-off valve, blood reservoir, blood pressure transducer and a continuous flushing system. The blood reservoir acts as the site where blood is conserved. When taking a sample, the reservoir is: (1) Pulled upwards to contain a volume of blood and also clear the arterial line, after which blood can be sampled from the sampling port. (2) After blood sampling is complete, the blood reservoir is pushed back down to reinfuse the blood it contains. Blood does not get discarded with closed-circuit arterial lines.

It has been found that 26-44% of ICU patients will receive a blood transfusion during their stay^{3,7,20}. Anaemia, on average, represents two-thirds of the indications for these transfusions in ICUs²¹. Additionally, it is estimated that 30% of blood transfusions in ICUs are the result of excessive blood sampling⁵. Transfusions can also have significant complications, including transfusion-associated circulatory overload (TACO), haemolysis and transfusion-related acute lung injury (TRALI)²². Therefore, minimising transfusions due to excessive blood sampling would reduce their associated risks and costs.

Objectives

1. To determine if significant blood loss occurred due to sampling, and to quantify the blood loss.
2. To collect and statistically analyse patient outcomes, haemoglobin values and transfusion data in correlation with blood loss due to sampling.

2. Methods

2.1 Study Design and Setting

A retrospective, single-centre observational study was performed to test blood sampling in critical ill patients. Patients admitted to an adult intensive care unit (ICU) within three months were used to gather the data. The patients who were in the ICU under level 3 care were studied.

2.2 The participants (Inclusion and Exclusion Criteria)

To be included in the study patients needed to have their ICU length of stay of 14 days or more and their level 3 care at some time during their stay. Patients were ineligible when they reported having any major bleeding incidents during their ICU stay, when they were deemed to have bone marrow suppression or when they had haemolytic anaemias.

2.3 Data Collection

The data contained in electronic patient records were analyzed to obtain clinical and demographic information, age, sex, co-morbidities, total length of ICU stay, and number of days under level 3 care. The information pertaining to blood sampling was gathered such as the kind and the regularity of blood tests. Data on blood transfusions, haemoglobin level at the ICU admission, nadir haemoglobin at the ICU admission and patient outcomes (28-day mortality at ICU admission and survival at discharge) were also collected. To measure blood volumes taken to be tested in the diagnosis section, the User Guide of the Pathology Department was consulted to find out the types of blood bottles and the respective volumes to be used in the cases of different investigations. (Table 2) provides the volumes relating to each type of blood bottle

Table 2: Author made. Blood Bottle Volumes. A description of the variety of blood bottles used in ICU sampling, the investigations performed from the sampled blood, and the volume of each bottle type.

Blood Bottle Type	Blood Test	Volume (mL)
EDTA K3 (Red)	Haematology	3.4
Citrate 3.2% (Green)	Coagulation	2.9
Serum Gel (Brown)	Serum Biochemistry	4.0
Fluoride/EDTA (Grey)	Ammonia/Tacrolimus/HbA1c	2.7
POCT Blood Gas Syringe	ABG	1.0
Blood Culture Bottle	Blood Culture	15.0

A sum of the number of point-of-care testing (POCT) arterial blood gas samples and other blood samples collected at different timepoints were summed to calculate the number of blood sampling episodes necessitating line clearance. Every sample episode of an intravascular catheter was preceded by a given volume of discard to clear the line of flush solution.

2.4 Definitions

The required standard of haemoglobin was of less than 120 g/L in women and less than 130 g/L in men as defined by the National Institute of Health and Care Excellence (NICE) standards. Since there is no NICE definition of severe anaemia, a haemoglobin level below 90 g/L was defined as severe anaemia, as per the literature published before.

Since no institutional guideline defined the amount of blood to be wasted before sampling, a questionnaire was given to the ICU nursing staff members to estimate the amount of the same. The discarded blood volumes, which were reported, were of 3 to 5 mL per episode of sampling. All analyses were done using the mean estimated discard volume of 4.1 mL.

2.5 Statistical Analysis

The statistical tests were conducted to measure the correlations between blood loss incurred during the sampling process and blood transfusion requirements, mortality, and haemoglobin decrease in relation to ICU length of stay. Linear associations were assessed using correlation coefficients as developed by Pearson. This was done by using analysis of covariance to compare the slope of regression across groups. The two-sided 95 percent confidence interval was used with a level of statistical significance being $p < 0.05$.

3. Results

32 patients were identified for inclusion in the study. Patient characteristics are summarised in (Table 3). Of the population, 46.9% were male, and 53.1% were female. The average age was 57 (± 14.3), ranging from 23-86 years old, with 18.8% being aged 70 years and over. The mean length of stay in the ICU was 24.0

days (± 8.9), with the longest ending after 44 days. The mean number of days in level 3 care was 20.2 days (± 10.0), approximately 4 days less than the total ICU length of stay.

Table 3: Author made. Summary of Patient Characteristics. Summarises demographic data from the patient population, including gender, age, length of stay in ICU and number of days receiving level 3 care.

Patient Characteristics	Mean (\pm SD)
Demographics	
Male (%)	46.9
Female (%)	53.1
Age (years)	57.1 (± 14.3)
Care Duration	
Total Length of ICU Stay (Days)	24.0 (± 8.9)
Days in Level 3 Care (Days)	20.2 (± 10.0)

3.1 Blood Loss Due to Sampling

In total, the whole patient population lost 18,497.5mL of blood when accounting for blood loss from both diagnostic tests and discarded blood volumes. For individual patients, the total blood loss over their whole ICU stay ranged from 287.4mL to 1,442.0mL. The mean total blood loss due to sampling was 578.0mL (± 242.3). The average daily blood loss per patient was 24.5mL/day (± 5.0), with volumes ranging from 15.0mL/day to 35.2mL/day.

The total number of blood tests performed across the patient population was 4,087 tests. The total number of tests performed on each patient was between 63 and 303 tests while they were in the ICU. The mean total number of blood tests was 127.7 (± 51.3). The daily average number of blood tests performed per patient was 5.3 (± 1.0), with values ranging between 3.6 and 7.6 tests per day. The most performed test was the POCT blood gas, which accounted for, on average, 50.8% (± 4.7) of all blood tests and 11.3% (± 1.0) of all blood volume lost. All data from blood loss due to sampling and blood tests performed are summarised in (Table 4).

Across the entire patient population, a total of 8,580.0mL of blood was discarded during 2,145 separate blood sampling episodes. Individual patients had a mean of 268.1mL (± 117.9) of blood discarded during their ICU stay, with volumes ranging from 116 to 716mL. This equated to an average of 11.4mL (± 2.8) of blood discarded daily, with volumes varying between 6.3 and 16.7mL/day. Blood discard volumes represented the highest proportion of blood lost due to sampling at 46.3% (± 3.5).

Table 4: Author made. Summary of Blood Loss from Sampling. Summarises the average volume of blood loss experienced by each patient and the proportions of different blood tests performed compared with the average total of all tests. It also shows the proportion of blood loss attributed to the different types of blood tests as a percentage and the mean volumes of blood loss due to discarded blood for each patient.

Blood Sampled	Mean (\pm SD)
Blood Loss per Patient	
Total Blood Loss (mL)	578.0 (± 242.3)
Daily Blood Loss (mL/day)	24.5 (± 5.0)
Proportions of Different Blood Tests Performed	
Total Number of Blood Tests	127.7 (± 51.3)
Daily Number of Blood Tests	5.3 (± 1.0)
POCT Blood Gases (%)	50.8 (± 4.7)
Haematology Tests (%)	18.2 (± 2.5)
Coagulation Screens (%)	8.1 (± 2.0)

Serum Biochemistry (%)	21.1 (±2.2)
Ammonia/Tacrolimus/HbA1c Tests (%)	0.4 (±0.9)
Blood Cultures (%)	1.4 (±1.2)
Proportion of Blood Loss Due to Different Blood Tests	
POCT Blood Gases (%)	11.3 (±1.0)
Haematology Tests (%)	13.8 (±2.3)
Coagulation Screens (%)	5.2 (±1.5)
Serum Biochemistry Tests (%)	18.8 (±2.5)
Ammonia/Tacrolimus/HbA1c Tests (%)	0.2 (±0.5)
Blood Cultures (%)	4.4 (±3.8)
Blood Loss from Discard Volumes per Patient	
Total Discarded Blood (mL)	268.1 (±117.9)
Daily Discarded Blood (mL/day)	11.4 (±2.8)
Proportion of Blood Loss from Discarded Blood (%)	46.3 (±3.5)

3.2 Blood Transfusions

Within the patient population, 37.5% of patients received a blood transfusion, with a total of 26 blood units being transfused. The mean number of blood units given across all patients was 0.8 units. The average daily blood volume sampled from patients who required one or more transfusions was 26.7mL/day (±6.2). The average daily volume of blood sampled from patients who did not receive a blood transfusion was less, at 23.2mL/day (±3.5).

The correlation between the total volume of blood loss, length of ICU stay and transfusion is demonstrated in Figure 2. A strong positive correlation was found between the volume of blood sampled, length of stay in the ICU and transfused patients ($r^2= 0.693$, $p= 0.0008$). A strong positive correlation was also found for the volume of blood sampled, length of stay in the ICU and non-transfused patients ($r^2= 0.771$, $p <0.0001$). However, the rate at which blood was lost due to sampling was not significantly higher in transfused patients than in those who were not transfused ($p= 0.0765$).

Relationship Between Blood Loss due to Sampling and Transfusion

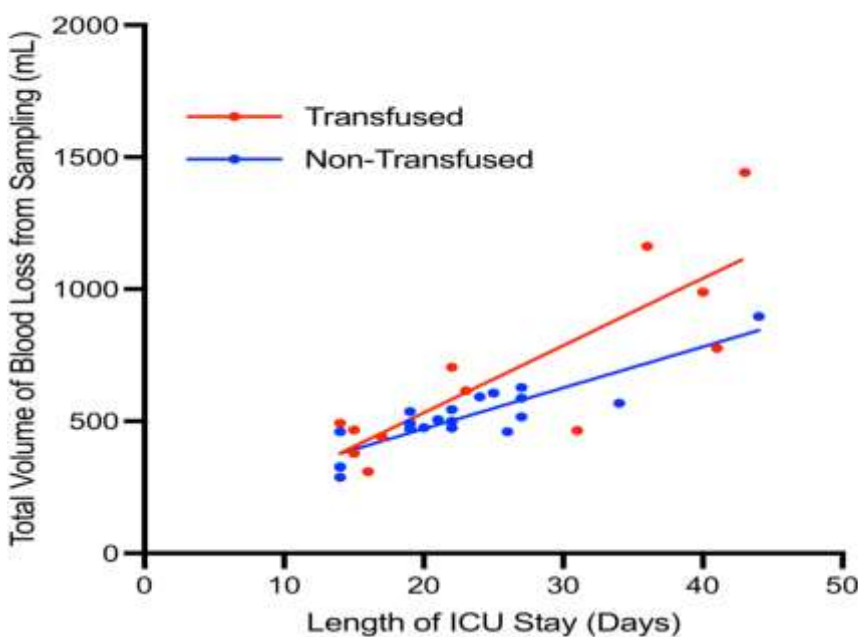

Figure 2: Author made. Relationship Between Blood Loss Due to Sampling and Transfusion. The graph shows the relationship between the total volume of blood lost from sampling and length of ICU stay for patients who received one or more blood transfusion (red), or did not receive a blood transfusion (blue) in the ICU, with their corresponding lines of regression.

3.3 Patient Outcomes

Within the patient population, three different patient outcomes were identified using survival-to-hospital discharge. These included those who did not survive to hospital discharge, those who did survive to hospital discharge and those who remained in the hospital at the conclusion of data collection. 28.1% of patients passed away before discharge, 50.0% survived to hospital discharge, and 21.9% remained in hospital after the study’s data collection was complete (49 days after last admission date). The highest daily blood loss due to sampling occurred in patients who passed away. For patients who did not survive to hospital discharge, 26.4mL/day (± 5.9) of blood was sampled on average. Patients who were discharged lost 24.7mL/day (± 4.3) of blood, and those who remained in the hospital lost 21.5mL/day (± 3.4). The highest proportion of blood transfusions were given to patients who did not survive to hospital discharge. Of the 9 patients who passed away, 55.6% received blood transfusions. Out of 16 patients who were discharged, 31.3% of patients were transfused. Of the 7 patients who remained in hospital, 28.6% received blood transfusions. The 28-day mortality for patients admitted to the ICU was 12.5%.

The correlation between the total volume of blood loss, length of ICU stay and patient outcome is demonstrated in Figure 3. A strong correlation was found between the volume of blood sampled, ICU length of stay and patients who did not survive to discharge ($r^2= 0.764$, $p= 0.0021$). A strong correlation was found between the volume of blood sampled, ICU length of stay and patients who survived to discharge ($r^2= 0.713$, $p < 0.0001$). A strong correlation was also found between the volume of blood sampled, length of stay in the ICU and patients who remained in the hospital after data collection completion ($r^2= 0.822$, $p= 0.0049$). The rate at which blood was lost due to sampling was significantly higher in patients who did not survive to discharge than those who survived to discharge or remained in hospital ($p= 0.0269$).

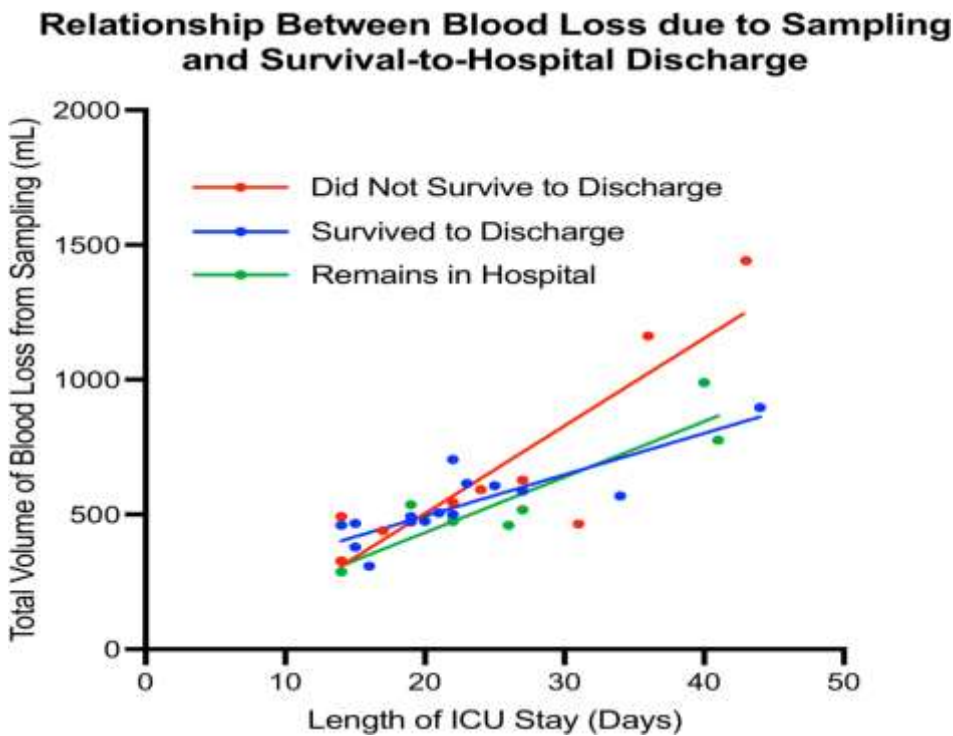

Figure 3: Author made. Relationship Between Blood Loss Due to Sampling and Survival-to-Hospital Discharge. The graph shows the relationship between the total volume of blood lost from sampling and length of ICU stay for patients who did not survive to hospital discharge (red), survived to hospital discharge

(blue), or remained in the hospital at the end of the data collection (green), with their corresponding lines of regression.

3.4 Haemoglobin Concentration

The average ICU admission haemoglobin concentration was 115.7g/L (± 21.0), and the average nadir haemoglobin during an ICU admission was 82.2g/L (± 16.0). The average decline in haemoglobin from admission to the nadir was 33.5g/L (± 15.1). 65.6% of the patient population were anaemic upon ICU admission, but 100% of the patient population were anaemic at some point during their ICU admission. 6.3% of patients were severely anaemic upon ICU admission, and 68.8% were severely anaemic at some point during their ICU admission.

The correlation between the total volume of blood loss, maximum haemoglobin decline and anaemia severity is demonstrated in Figure 4. No correlation was found between the total volume of blood loss and maximum decline in haemoglobin for patients who developed severe anaemia ($r^2 = 0.000$, $p = 0.9638$). Furthermore, no correlation was found between the total volume of blood loss and maximum decline in haemoglobin for patients who did not develop severe anaemia ($r^2 = 0.138$, $p = 0.2907$). As there is no linear correlation, no significance can be drawn from their relationships.

Relationship Between Blood Loss due to Sampling and the Maximum Decline in Haemoglobin

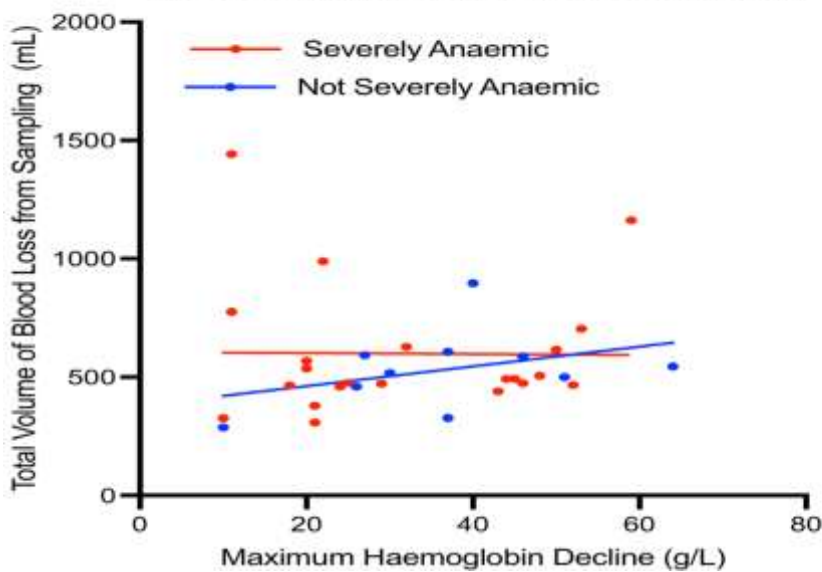

Figure 4: Author made. Relationship Between Blood Loss Due to Sampling and Maximum Haemoglobin Decline in Different Severities of Anaemia. The graph shows the relationship between the total volume of blood lost from sampling and the maximum decline in haemoglobin concentration for patients who developed severe anaemia in the ICU (red) or those who did not develop severe anaemia in the ICU (blue), with their corresponding lines of regression.

4. Discussion

A large volume of blood was drawn from patients for sampling in the ICU, with an average of 24.5mL of blood taken each day. This finding is in keeping with volumes of blood loss seen in previous studies, which have observed between 18-86mL of blood sampled per day^{7,9,10-12}. A significant proportion was not used for the purposes of testing and monitoring. Just under half (46.3%) of all blood loss patients experienced was wasted by being discarded for line clearance. This accounted for an average of 11.4mL/day of discarded blood. The discard volume was slightly lower than the 13-15mL/day of blood discarded for each patient seen in past studies^{9,10,14}. Despite this, however, a much greater proportion of blood was discarded than the 30% typically expected when using conventional arterial lines¹².

Furthermore, the most frequently performed blood test was POCT blood gases. They accounted for just over half (50.8%) of all investigations requiring a blood sample. This is similar to a past study that stated POCT blood gases represented 40% of all blood tests performed in the ICU²⁶, although it may suggest a slightly higher reliance on POCT. Interestingly, the POCT blood gas analysis only accounted for 11.3% of total blood volume loss. Whilst this can be considered an impressive ratio of sampling frequency to blood volume lost, greater improvements can be made to reduce the volume further. The highest sources of blood loss due to sampling for laboratory testing occurred due to serum biochemistry and haematology, representing 18.8% and 13.8% of total blood loss, respectively.

This study found no statistically significant difference between the volume of blood sampled from patient groups who received blood transfusions and those who did not. Patients requiring transfusions lost, on average, 3.5mL/day more blood than those who did not require a transfusion. Despite each group having a strong positive correlation between the volume of blood lost with the time spent in the ICU, it could not be concluded that patients who received blood transfusions lost more blood due to blood sampling. This is contrary to past literature, which has found that correlations between higher blood sampling volumes and transfusion requirements exist^{10, 27, 28}. Patients who require blood transfusions in critical care have also been linked to poorer outcomes, although the likely explanation for this is a combination of blood sampling practices and the severity of patients' critical illness^{3, 7}. Therefore, while it is not possible to consider blood sampling as an independent predictor of transfusion requirements from the study's results, they demonstrate it is likely part of a group of variables which all contribute towards patients requiring transfusions. It is notable that more extensive blood testing is required for more severely ill patients. As a result, the extent to which blood sampling increases the likelihood that patients will require blood transfusions cannot be determined. This is an area that will require further exploration to assess the scale at which blood sampling can be used to predict transfusion requirements.

Unsurprisingly, anaemia was identified as a complication in 100% of patients admitted to the ICU, with the average maximum decline in haemoglobin concentration being 33.5g/L. However, no correlation was found between the decrease in haemoglobin concentration and the volume of blood loss due to sampling. This is similar to results produced in other studies with a comparable methodology, where declines in haemoglobin concentration were observed after ICU admission, but no relationship could be drawn between haemoglobin and blood sampling^{11, 29}. Despite iatrogenic blood loss being an undeniable source of anaemia in ICU patients, it is uncertain to what extent it contributes to the overall haemoglobin decline. Many reasons could be responsible for the lack of a correlation between blood sampling and haemoglobin concentration, as shown in (Table 1).

The primary blood conservation method that can be introduced is closed-circuit arterial lines. The theoretical application of these devices may reduce the total blood loss from sampling by almost half (46.3%). However, a previous systematic review of best practice using closed-circuit arterial lines only demonstrated a reduction in blood loss by approximately 25%³⁰. Their use has been reported to significantly lower both transfusion requirements and improve mortality rates for ICU patients³¹. Their proposed use should be subject to further quality improvement projects and randomised control trials to determine their effectiveness in reducing blood loss. Closed-circuit arterial lines are more expensive than the conventional arterial lines currently in use³². Despite this, they may be considered cost-effective when equated to possible financial savings made from a reduction in transfusion frequency and the adverse effects related to blood transfusions²² as well as improved patient outcomes.

Furthermore, blood loss from sampling can be further reduced by limiting excessive blood testing. This may be achievable through lead physicians selecting and rationalising daily blood tests as required – using their expertise to determine which investigations will best assist efforts to monitor individual patients. Literature relating to the optimisation of blood sampling suggests that currently, half of the blood tests patients receive in the ICU are unnecessary^{14, 15}.

5. Limitations

Several limitations were present during the study. Firstly, the study used a retrospective design, whereas a prospective study may have provided more accurate results. Difficulties were present in obtaining accurate blood sampling and discarded volumes retrospectively. However, results from the questionnaire allowed average volumes of discarded blood to be gauged, which were similar to previous studies on the same topic. Furthermore, the electronic patient records system used for data collection did not include all blood samples patients received, such as group and save and cross-matching samples. A prospective analysis would have instead allowed for the volumes to be tracked at the time of sampling from each individual patient, making the averages calculated more accurate. However, it is not expected that this factor will change the results significantly. Additionally, the size of the study population was small and from a single-centre, meaning that although some results were found to be significant, caution is advised when making generalisations from them.

Finally, discarded blood volumes cannot be considered as entirely undiluted blood due to the use of saline flushes. A proportion of the discarded blood volumes was composed of saline. Therefore, it is not possible to determine the extent to which these diluted blood volumes affected the end volumes calculated. Importantly, the absence of a scoring system to determine illness severity meant it was a potential confounding variable for the survival-to-hospital discharge of patients. Scoring systems such as the acute physiology and chronic health evaluation II (APACHE II) was used in past studies to eliminate illness severity from being a potential confounder for mortality^{9, 11, 12}.

6. Conclusions

This study demonstrated that ICU patients experienced high volumes of blood loss. Reductions in discarded blood volumes and sampling frequency have been identified as areas that could significantly benefit patient care and reduce the harm critically ill patients may experience. Ultimately, the quality-of-care patients experience in the ICU may be improved through the application of blood conservation methods. Further studies are recommended into blood loss due to sampling in ICUs, as well as additional research to assess the efficacy of blood conservation methods

Statements and Declarations

Consent to participate

Not applicable.

Consent for publication

Not applicable.

Declaration of conflicting interest

The author(s) declared no potential conflicts of interest with respect to the research, authorship, and/or publication of this article.

Funding

The author(s) received no financial support for the research, authorship, and/or publication of this article.

Data availability

The datasets generated and/or analysed during the current study are available from the corresponding author on reasonable request.

Author Contributions

JN and OE conceptualised the study and collected data. JN performed data analysis. OE and TS contributed to interpretation of results. JN drafted the manuscript. All authors critically revised the manuscript and approved the final version.

References

1. Hayden SJ, Albert TJ, Watkins TR, Swenson ER. Anemia in critical illness: insights into etiology, consequences, and management. *American journal of respiratory and critical care medicine*. 2012 May 15;185(10):1049-57.
2. Rawal G, Kumar R, Yadav S, Singh A. Anemia in intensive care: a review of current concepts. *The Journal of Critical Care Medicine*. 2016 Aug 10;2(3):109-14.

3. Corwin HL, Gettinger A, Pearl RG, Fink MP, Levy MM, Abraham E, MacIntyre NR, Shabot MM, Duh MS, Shapiro MJ. The CRIT Study: anemia and blood transfusion in the critically ill—current clinical practice in the United States. *Critical care medicine*. 2004 Jan 1;32(1):39-52.
4. Astin R, Puthuchearu Z. Anaemia secondary to critical illness: an unexplained phenomenon. *Extreme physiology & medicine*. 2014 Dec;3(1):1-9.
5. Walsh TS, Saleh EE. Anaemia during critical illness. *BJA: British Journal of Anaesthesia*. 2006 Sep 1;97(3):278-91.
6. McEvoy MT, Shander A. Anemia, bleeding, and blood transfusion in the intensive care unit: causes, risks, costs, and new strategies. *American Journal of Critical Care*. 2013 Nov;22(6):eS1-3.
7. Vincent JL, Baron JF, Reinhart K, Gattinoni L, Thijs L, Webb A, Meier-Hellmann A, Nollet G, Peres-Bota D, ABC investigators, ABC Investigators. Anemia and blood transfusion in critically ill patients. *Jama*. 2002 Sep 25;288(12):1499-507.
8. Corwin HL, Parsonnet KC, Gettinger A. RBC transfusion in the ICU: is there a reason?. *Chest*. 1995 Sep 1;108(3):767-71.
9. Ullman AJ, Keogh S, Coyer F, Long DA, New K, Rickard CM. ‘True Blood’The Critical Care Story: An audit of blood sampling practice across three adult, paediatric and neonatal intensive care settings. *Australian critical care*. 2016 May 1;29(2):90-5.
10. Bodley T, Chan M, Levi O, Clarfield L, Yip D, Smith O, Friedrich JO, Hicks LK. Patient harm associated with serial phlebotomy and blood waste in the intensive care unit: A retrospective cohort study. *PLoS One*. 2021 Jan 13;16(1):e0243782.
11. Cioc A, Fodor R, Benedek O, Moldovan A, Copotoiu SM. Blood sampling as a cause of anemia in a general ICU—a pilot study. *Romanian Journal of Anaesthesia and Intensive Care*. 2015 Apr;22(1):13.
12. Holland J, Peralta RM, Moss RL, Feane K, Uprichard J. A single-centre review of iatrogenic anaemia in adult intensive care. *Transfusion Medicine*. 2020 Jun;30(3):196-200.
13. Thavendiranathan P, Bagai A, Ebidia A, Detsky AS, Choudhry NK. Do blood tests cause anemia in hospitalized patients? The effect of diagnostic phlebotomy on hemoglobin and hematocrit levels. *Journal of general internal medicine*. 2005 Jun;20:520-4.
14. Mikhaeil M, Day BA, Ilan MR. Non-essential blood tests in the intensive care unit: a prospective observational study Tests sanguins non essentiels al’unité de soins intensifs: une étude observationnelle prospective. *Can J Anesth/J Can Anesth*. 2017;64:290-5.
15. Cismondi F, Celi LA, Fialho AS, Vieira SM, Reti SR, Sousa JM, Finkelstein SN. Reducing unnecessary lab testing in the ICU with artificial intelligence. *International journal of medical informatics*. 2013 May 1;82(5):345-58.
16. Pour-Ghaz I, Manolukas T, Foray N, Raja J, Rawal A, Ibebuogu UN, Khouzam RN. Accuracy of non-invasive and minimally invasive hemodynamic monitoring: where do we stand?. *Annals of Translational Medicine*. 2019 Sep;7(17).
17. Thomas J, Jensen L, Nahirmiak S, Gibney RN. Anemia and blood transfusion practices in the critically ill: a prospective cohort review. *Heart & Lung*. 2010 May 1;39(3):217-25.
18. Oto J, Nakataki E, Hata M, Tsunano Y, Okuda N, Imanaka H, Nishimura M. Comparison of bacterial contamination of blood conservation system and stopcock system arterial sampling lines used in critically ill patients. *American journal of infection control*. 2012 Aug 1;40(6):530-4.
19. Thorpe S, Thomas AN. The use of a blood conservation pressure transducer system in critically ill patients. *Anaesthesia*. 2000 Jan;55(1):27-31.
20. Vincent JL, Jaschinski U, Wittebole X, Lefrant JY, Jakob SM, Almekhlafi GA, Pellis T, Tripathy S, Rubatto Birri PN, Sakr Y, ICON Investigators. Worldwide audit of blood transfusion practice in critically ill patients. *Critical care*. 2018 Dec;22:1-9.
21. Cable CA, Razavi SA, Roback JD, Murphy DJ. RBC transfusion strategies in the ICU: a concise review. *Critical care medicine*. 2019 Nov;47(11):1637.
22. Bolton-Maggs PH, Cohen H. Serious Hazards of Transfusion (SHOT) haemovigilance and progress is improving transfusion safety. *British journal of haematology*. 2013 Nov;163(3):303-14.
23. National Institute for Health and Care Excellence. Interpreting a full blood count [Internet]. Available from: <https://cks.nice.org.uk/topics/anaemia-iron-deficiency/diagnosis/investigations/#interpreting-a-full-blood-count> [Accessed 20th May 2023].

24. Baysan M, Arbous MS, van der Bom JG. Iatrogenic anemia: an underestimated and solvable problem in the intensive care unit. *Ann Blood*. 2020;5:19.
25. Jackson Chornenki NL, James TE, Barty R, Liu Y, Rochweg B, Heddle NM, Siegal DM. Blood loss from laboratory testing, anemia, and red blood cell transfusion in the intensive care unit: a retrospective study. *Transfusion*. 2020 Feb;60(2):256-61.
26. Fowler RA, Berenson M. Blood conservation in the intensive care unit. *Critical care medicine*. 2003 Dec 1;31(12):S715-20.
27. Leahy MF, Hofmann A, Towler S, Trentino KM, Burrows SA, Swain SG, Hamdorf J, Gallagher T, Koay A, Geelhoed GC, Farmer SL. Improved outcomes and reduced costs associated with a health-system-wide patient blood management program: a retrospective observational study in four major adult tertiary-care hospitals. *Transfusion*. 2017 Jun;57(6):1347-58.
28. Chant C, Wilson G, Friedrich JO. Anemia, transfusion, and phlebotomy practices in critically ill patients with prolonged ICU length of stay: a cohort study. *Critical care*. 2006 Oct;10:1-9.
29. Ba VN, Bota DP, Mélot C, Vincent JL. Time course of hemoglobin concentrations in nonbleeding intensive care unit patients. *Critical care medicine*. 2003 Feb 1;31(2):406-10.
30. Whitehead NS, Williams LO, Meleth S, Kennedy SM, Ubaka-Blackmoore N, Geaghan SM, Nichols JH, Carroll P, McEvoy MT, Gayken J, Ernst DJ. Interventions to prevent iatrogenic anemia: a Laboratory Medicine Best Practices systematic review. *Critical Care*. 2019 Dec;23:1-1.
31. Keogh S, Mathew S, Ullman AJ, Rickard CM, Coyer F. What blood conservation practices are effective at reducing blood sampling volumes and other clinical sequelae in intensive care? A systematic review. *Australian Critical Care*. 2023 Jan 10.
32. Page C, Retter A, Wyncoll D. Blood conservation devices in critical care: a narrative review. *Annals of intensive care*. 2013 Dec;3:1-6.